

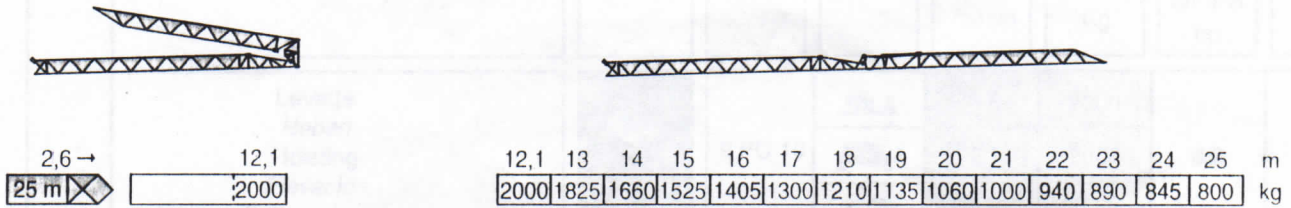

**Courbes de charges - Lastkurven - Load diagrams - Curvas de cargas - Curve di carico**

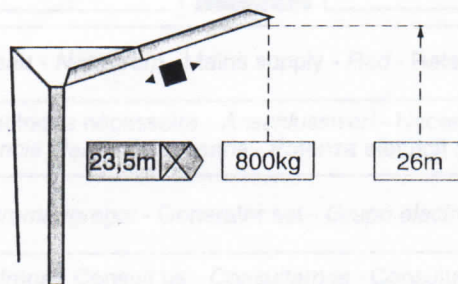

**Flèche relevée - Ausleger in Steilstellung - Luffing jib - Flecha izada - Braccio impennato**



**2 D2 V4**



Chariot distributeur  
Verfahrbare laufkatze  
Traversing trolley  
Carro distribuidor  
Carrellino distributore

**Réaction - Eckdrücke - Reactions - Reacciones - Reazioni**

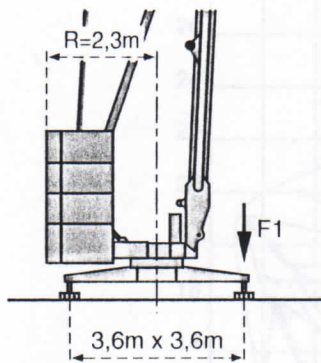

F1 (R=2,3m)	● 12,3t	■ 6,8t
----------------	---------	--------

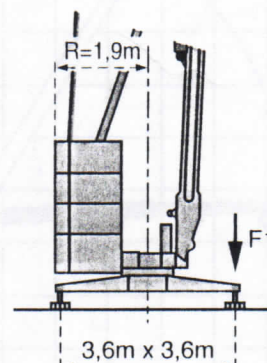

F1 (R=1,9m)	● 13,4t	■ 7,9t
----------------	---------	--------

	7,4t
---	------

● En service  
■ Hors service

● In Betrieb  
■ Ausser Betrieb

● In service  
■ Out of service

● En servicio  
■ Fuera de servicio

● In servizio  
■ Fuori servizio

 A vide sans lest ni train de transport avec flèche et hauteur maximum.

 Ohne Last, Ballast und Transportachse, mit Maximalausleger und Maximalhöhe.

 Without load, ballast or transport axles, with maximum jib and maximum height

 Sin carga, sin lastre, ni tren de transporte, flecha y altura máximas.

 A vuoto, senza zavorra ne assali di trasporto con braccio massimo e altezza massima.