

GMR HD 40 A

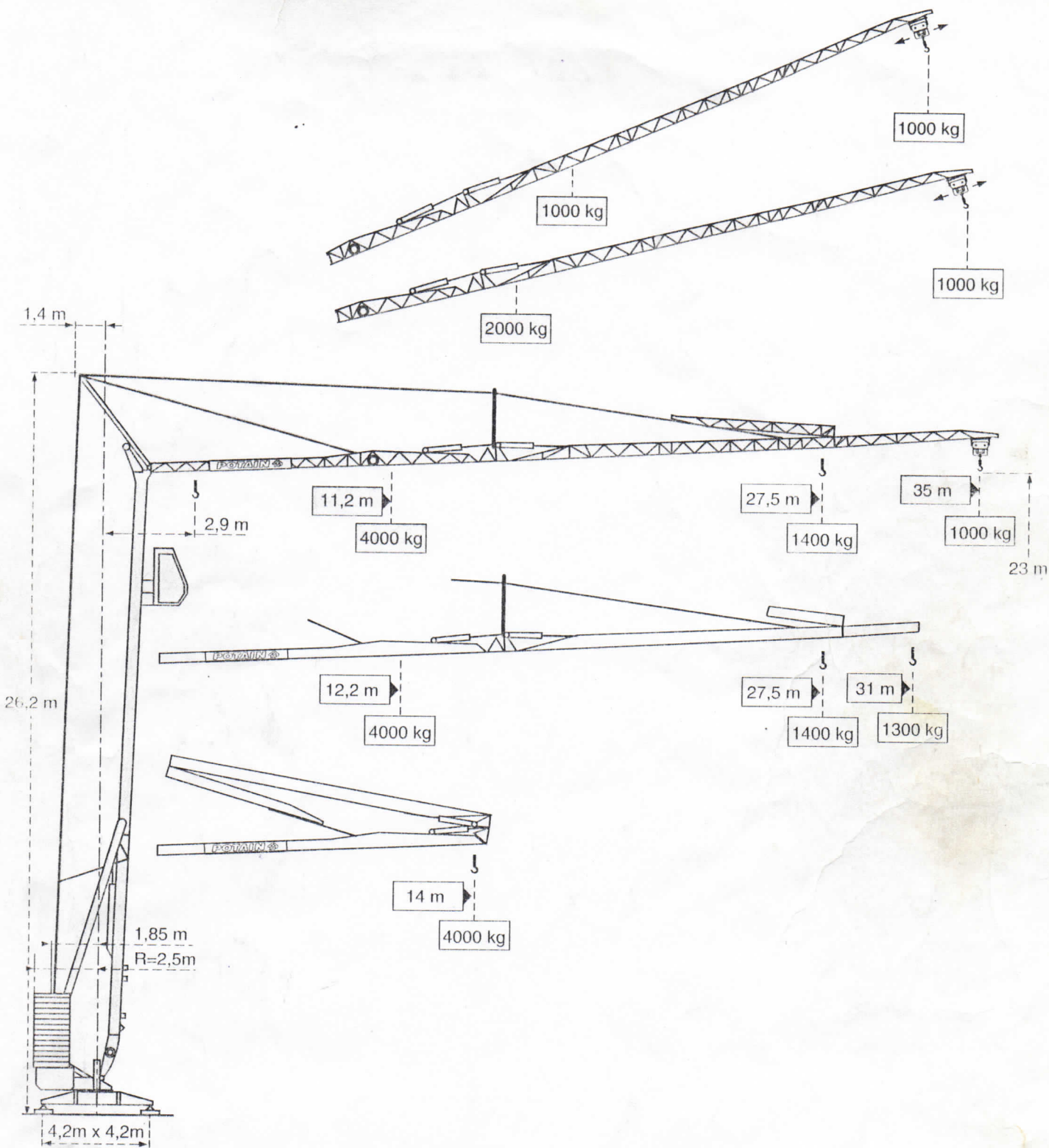

# GMR HD 40 A

LIN 1

# POTAIN



**Courbes de charges - Lastkurven - Load diagrams - Curvas de cargas - Curve di carico**

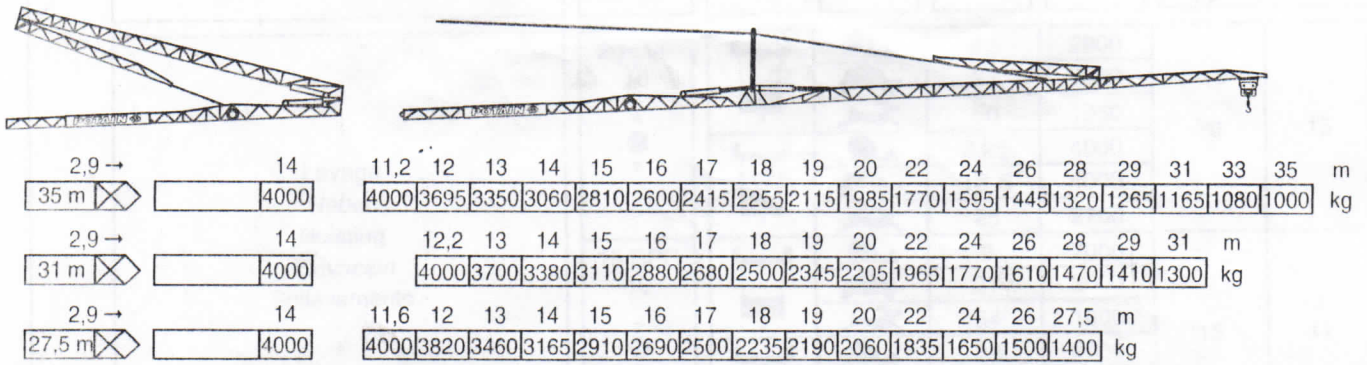

**Flèche relevée - Ausleger in Steilstellung - Luffing jib - Flecha izada - Braccio impennato**

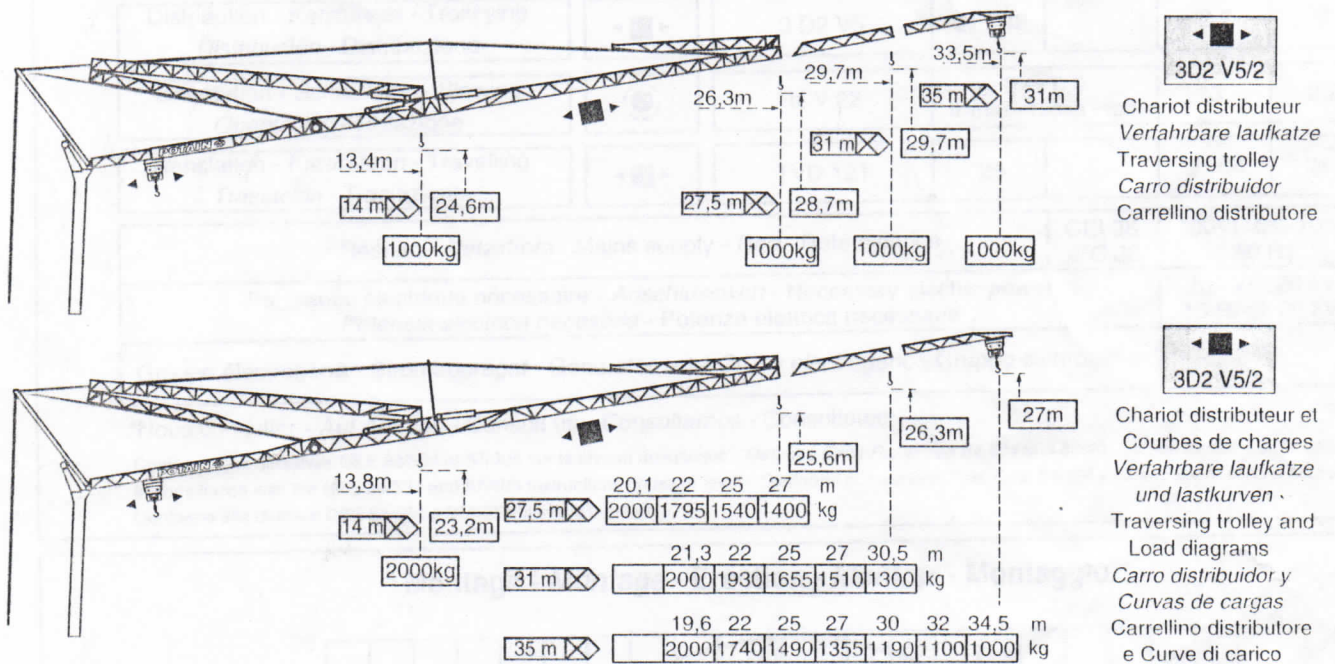

**Réaction - Eckdrücke - Reactions - Reacciones - Reazioni**

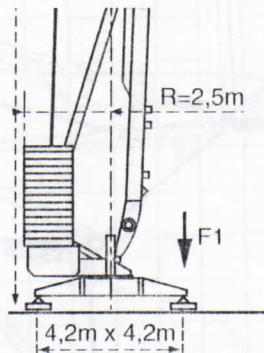

F1	● 22,5t	■ 15,8t
	12,3t	

● En service  
 ■ Hors service

● In Betrieb  
 ■ Ausser Betrieb

● In service  
 ■ Out of service

● En servicio  
 ■ Fuera de servicio

● In servizio  
 ■ Fuori servizio

 A vide sans lest ni train de transport avec flèche et hauteur maximum.

 Ohne Last, Ballast und Transportachse, mit Maximalausleger und Maximalhöhe.

 Without load, ballast or transport axles, with maximum jib and maximum height.

 Sin carga, sin lastre, ni tren de transporte, flecha y altura máxima.

 A vuoto, senza zavorra ne assali di trasporto con braccio massimo e altezza massima.



Transport - *Transport* - Transport - *Transporte* - Trasporto

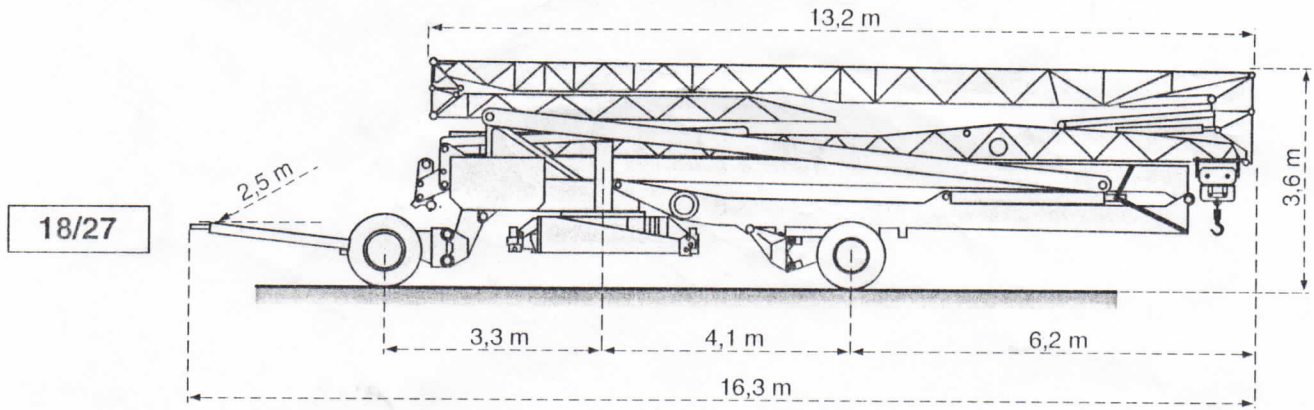

18/27

- DS95/S105
- DJ125/S105
- DS80/J100

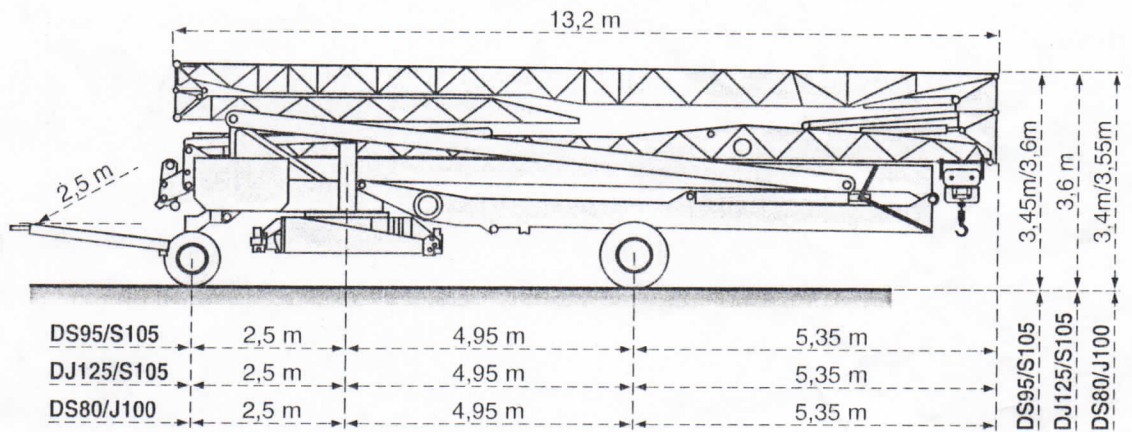

DS95/S105	2,5 m	4,95 m	5,35 m
DJ125/S105	2,5 m	4,95 m	5,35 m
DS80/J100	2,5 m	4,95 m	5,35 m

- Chantier
- Baustelle
- Site
- Obra
- Cantiere



NF E 52081 - 82  
DIN 15018.H1 B3

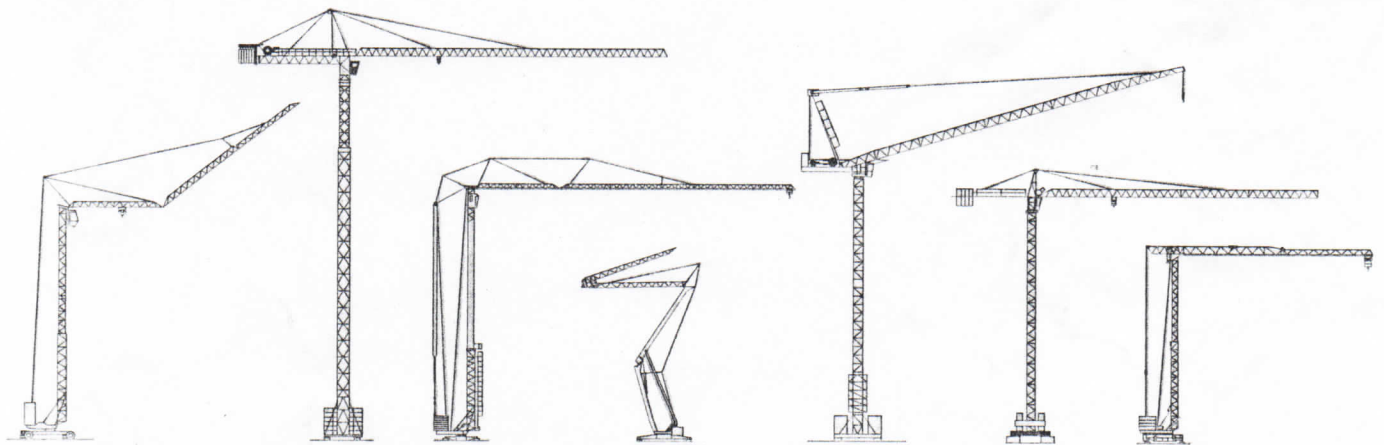

Document pour usage commercial uniquement - *Benutzung dieser Unterlagen nur für Verkaufszwecke* - Document for commercial use only -  
*Documento para uso comercial unicamente* - Documento per uso commerciale solamente

Copyright.Reproduction interdite © POTAIN 1995

**POTAIN**

GRUPE *LEGRIS* INDUSTRIES

18.Rue de Charbonnières, B.P. 173-F 69132 ECULLY Cedex  
Tél. 72.20.20.20 - Télex 375 213 - Fax 72.20.20.00  
POTAIN GmbH Deutschland Tel : 06.105.704.0  
POTAIN U.K. Great Britain Tel : 0895.44.52.61  
Simma POTAIN Italia Tel : 02.97.96.71  
POTAIN Portugal Portugal Tel : 02.968.08.89

GMR HD 40 A

Réf. 1995.04 LIN 1

Modifiche riservate

Modificaciones reservadas

Subject to modification

Änderungen vorbehalten

Modifications réservées

Printed in France

Realisation SODIPE