

Igo 36

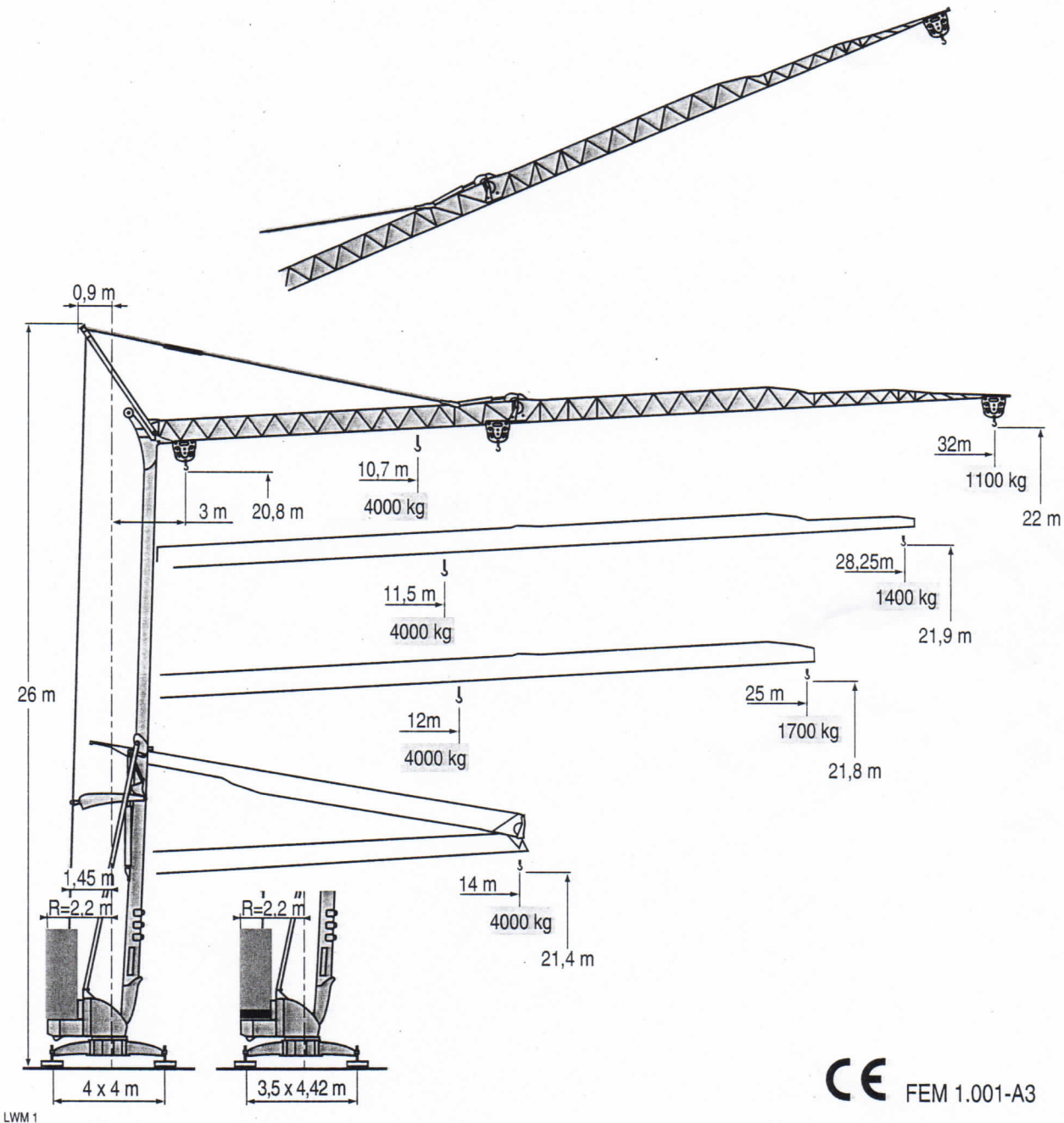

- Igo
HD
HDM
- HDT
- GTMR
- CITY CRANE
- TOPKIT MD
MAXI MD
- MAXI TOPKIT
- Topless MDT
- MR



POTAIN

Courbes de charges
Lastkurven



Load diagrams
Curvas de cargas



Curve di carico
Curva de cargas

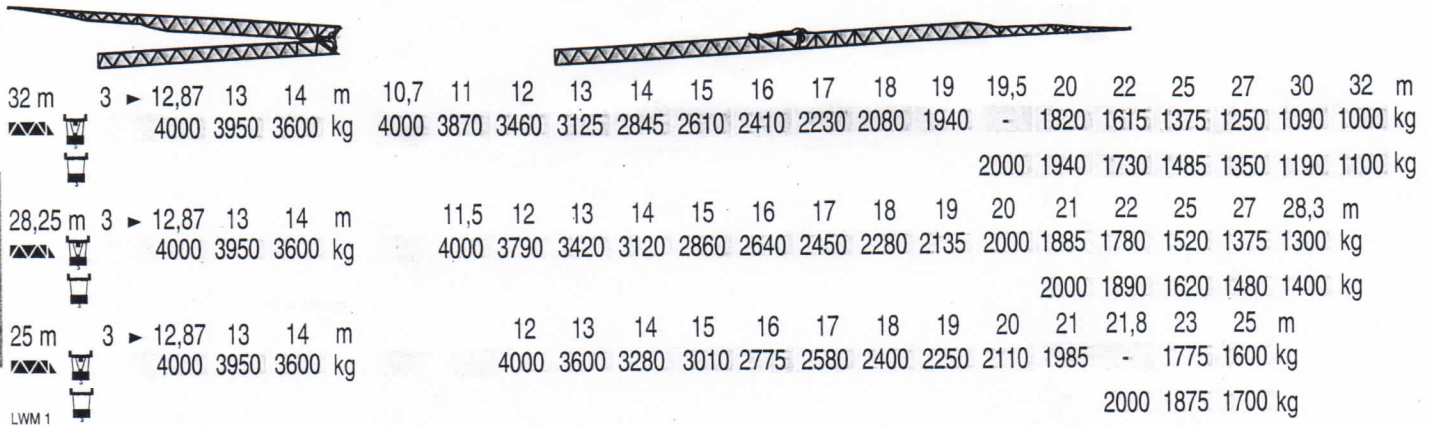

Flèche relevée
Ausleger in Steilstellung



Luffing jib
Flecha izada



Braccio impennato
Lança inclinada

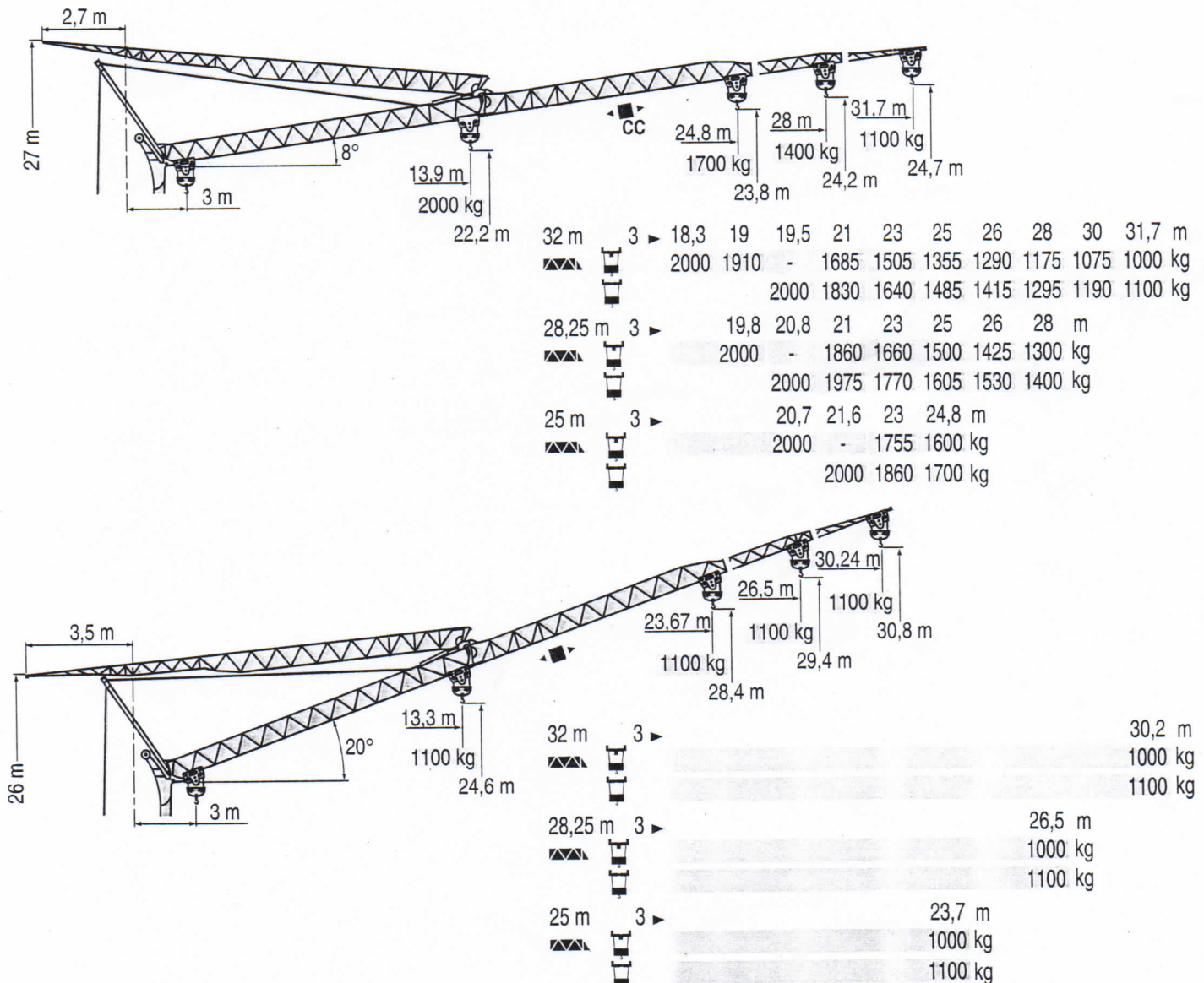

- Chariot distributeur
- F
- Verfahrbare laufkatze
- D
- Traversing trolley
- GB
- Carro distribuidor
- E
- Carrellino distributore
- I
- Carro distribuidor
- P

Réactions
Eckdrücke



Reactions
Reacciones



Reazioni
Reacções

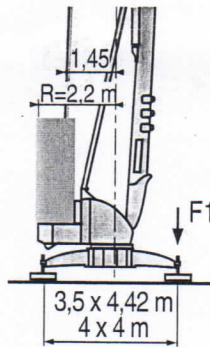

F1 • 20 t ■ 16,3 t

▲ 10,4 t

LWM 1

●	Réactions en service	F	Reaktionskräfte in Betrieb	D	Reactions in service	GB	Reacciones en servicio	E	Reazioni in servizio	I	Reacções em serviço	P
■	Réactions hors service		Reaktionskräfte außer Betrieb		Reactions out of service		Reacciones fuera de servicio		Reazioni fuori servizio		Reacções fora de serviço	
▲	A vide sans lest (ni train de transport) avec flèche et hauteur maximum		Ohne Last, Ballast (und Transportachse), mit Maximalausleger und Maximalhöhe.		Without load, ballast (or transport axles), with maximum jib and maximum height.		Sin carga, sin lastre, (ni tren de transporte), flecha y altura máxima.		A vuoto, senza zavorra (ne assali di trasporto) con braccio massimo e altezza massima.		Sem carga (nem trem de transporte)- sem lastro com lança e altura máximas.	

Mécanismes
Antriebe



Mechanisms
Mecanismos



Meccanismi
Mecanismos



												ch - PS hp	kW	
▲	15 LVF 10 Optima	m/min	3,4	28	47	52	68	1,7	8,6	14	26	34	15	11
		kg	2000	2000	1100	1000	500	4000	4000	4000	2000	1000		
◀ ▶	3 DVF5	m/min	0 → 10 → 41										4	3
⊙	RVF2	tr/min U/min rpm	0 → 0,8										3	2,2

CEI 38	IEC 38	kVA	
400 V (+6% -10%) 50 Hz		20 kVA	2000 /14

15 LVF 10
Optima

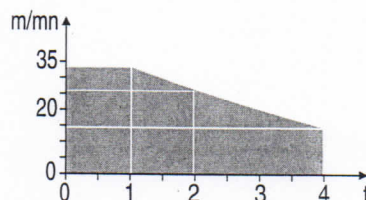

LWM 1

▲	Levage	F	Heben	D	Hoisting	GB	Elevación	E	Sollevamento	I	Elevação	P
◀ ▶	Distribution		Katzfahren		Trolleying		Distribución		Distribuzione		Distribuição	
⊙	Orientation		Schwenken		Slewing		Orientación		Rotazione		Rotação	
🔊	Conforme aux directives CEE 84/534 et 87/405 sur le niveau acoustique		Gemäss EWG-Richtlinien 84/534 und 87/405 für den Schall-Leistungspegel		In compliance with the EEC 84/534 and 87/405 Instructions on noise level		Conforme con las directivas CEE 84/534 y 87/405 sobre el nivel acustico		Conforme alle direttive CEE 84/534 e 87/405 sul livello acustico		Conforme as directivas CEE 84/534 e 87/405 sobre o nível acústico	

Montage
Montage



Erection
Montaje



Montaggio
Montagem

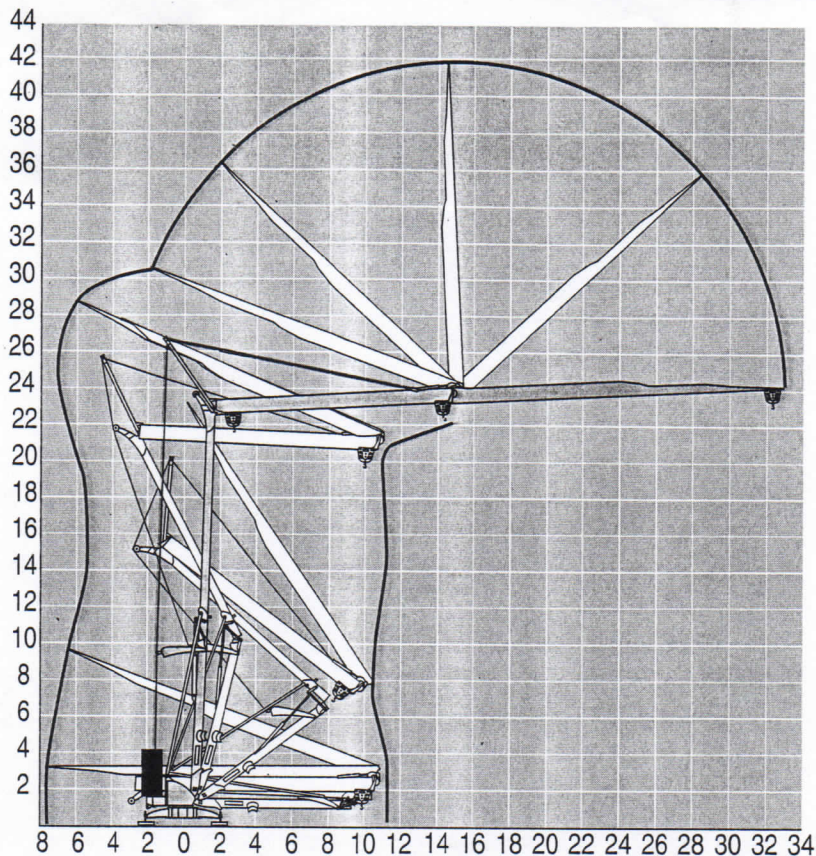

Transport
Transport



Transport
Transporte



Trasporto
Transporte



	L			H		L	
	16.03 m	14 m	10.81 m	3.58 m			
	16.03 m	14 m	10.81 m				
SL122/J215M	3,34 m	4,07 m	6,74 m				
SL121/J135	3,34 m	4,15 m	6,66 m				
SL121/S215M	3,34 m	4,07 m	6,74 m				
DS60/J100	2,35 m	3,73 m	7,08 m	3,05/3,20 m	15,67 m		
DS60/S105	2,35 m	3,73 m	7,08 m	3,05/3,20 m	15,67 m		
DS80/J100	2,45 m	4,15 m	6,66 m	3,10 m	15,90 m		
DS95/S105	2,45 m	4,15 m	6,66 m	3,23 m	16,33 m		
DJ126M/S105	2,45 m	4,15 m	6,66 m	3,20 m	16,35 m		
DJ126M/S215M	3,24 m	4,07 m	6,74 m	3,55 m	17,14 m		
CJ125M/J215M	3,24 m	4,07 m	6,74 m	3,55 m	17,40 m		

SL122/J215M

SL121/J135

SL121/S215M

CJ125M/J215M

DJ126M/S215M

DJ126M/S105

DS60/J100 ○

DS60/S105

DS80/J100 ○

DS95/S105

LWM 1



Chantier



Baustelle



Site



Obra



Cantiere



Estaleiro



Document commercial non contractuel. Pour toute information technique se référer à la notice correspondante

Unverbindliches Vertriebsdokument. Für technische Informationen, siehe die entsprechenden Anweisungen.

This commercial document is not legally binding. For any technical information, please refer to the corresponding instructions.

Documento comercial no contractual. Para cualquier información técnica, ver la noticia correspondiente.

Documento commerciale non vincolante, per tutte le informazioni tecniche fare riferimento al catalogo istruzioni

Documento comercial não contratual. Para qualquer informação técnica complementar consultar as respectivas instruções

POTAIN

18, Rue de Charbonnières, B.P. 173
F-69132 ECULLY Cedex
Tél. (33)04.72.18.20.20
Fax (33)04.72.18.20.00
<http://www.potain.com>
E-mail : mkt@potain.fr



Manitowoc Crane Group

Deutschland
POTAIN GmbH
Italia
POTAIN S.p.A.
Portugal
POTAIN Portugal
Singapore
MANITOWOC POTAIN PTE LTD

Tel : 06.1.05.70.40

Tel : 0.331.49.33.11

Tel : 22.968.08.89

Tel : 227.15.50

Copyright.Reproduction interdite © POTAIN 2001

Igo 36

Réf. 2002.20 LWM 1

Reserva de modificaciones / Modifiche riservate / Modificaciones reservadas / Subject to modification / Änderungen vorbehalten / Modificações reservadas

Printed in France

Réalisation HeadLines