

Igo T 70 A

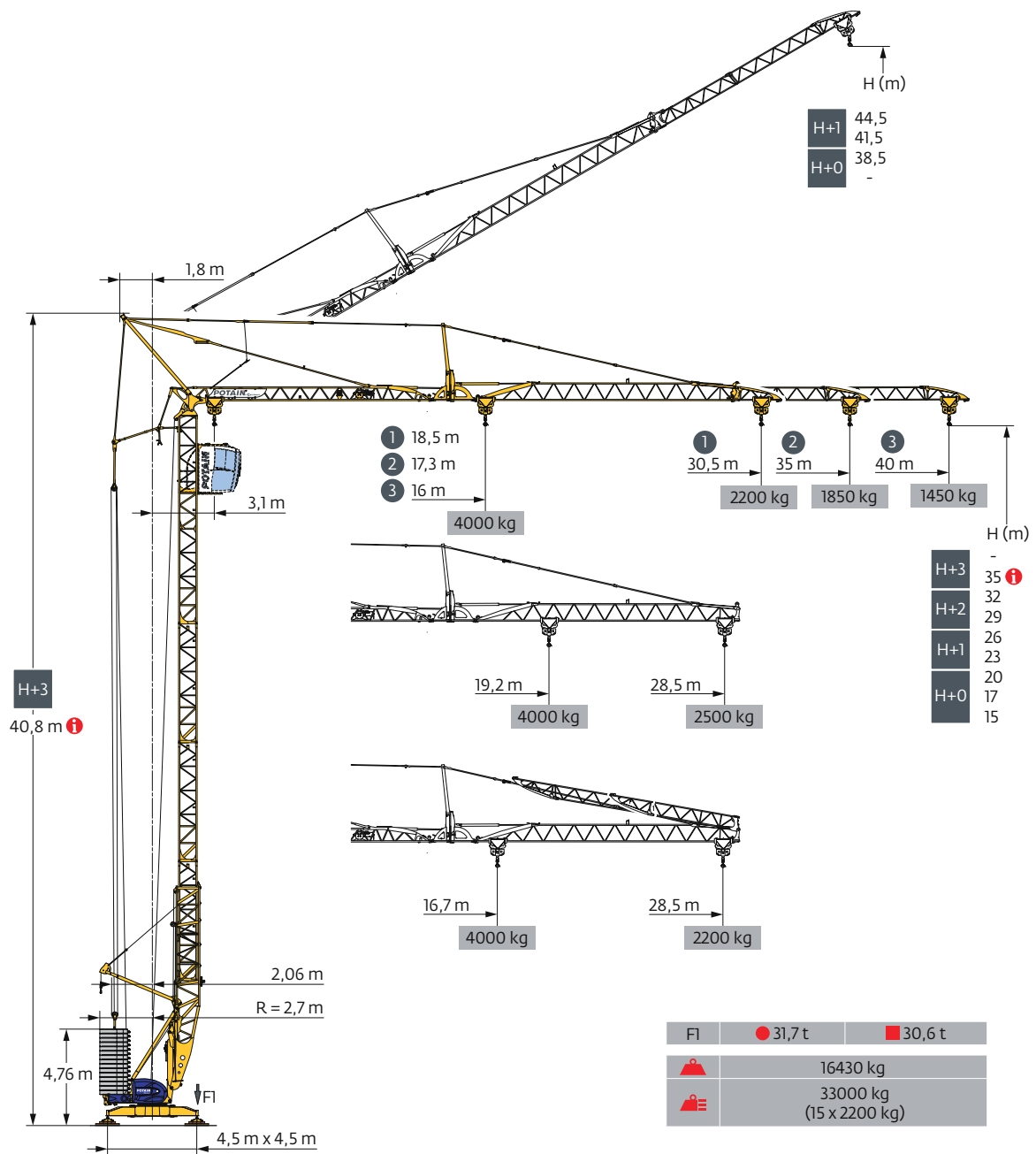

SmartCom

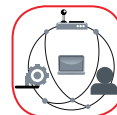

Top Zone

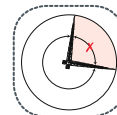

Top Tracing II

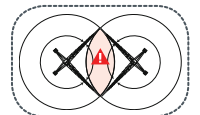

Courbes de charges / Lastkurven / Load curves / Curvas de cargas / Curve di carico
 Curvas de carga / Кривые нагрузок

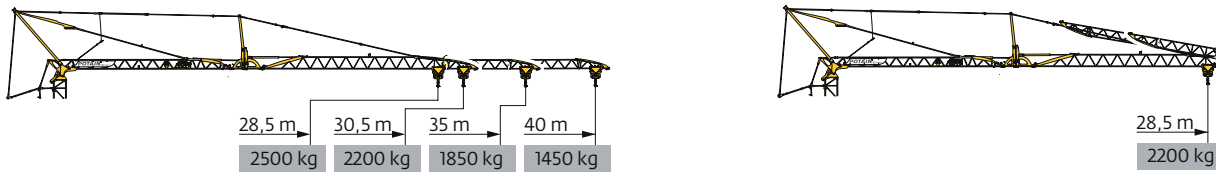

40 m	3,1	▶		16	18	20	22	24	26	26,2	28	30	32	34	36	38	40	m
▲▲▲	▲▲▲	▲▲▲	▲▲▲	4000	3470	3060	2720	2450	2220	2200	2030	1860	1720	1600	1490	1390	1300	kg
										2200	2030	1860	1720	1600	1490	1390	1300	kg
										2200	2050	1900	1750	1650	1550	1450		kg
35 m	3,1	▶		17,3	18	20	22	24	26	28	28,4	30	32	34	35		m	
▲▲▲	▲▲▲	▲▲▲	▲▲▲	4000	3800	3350	2990	2690	2440	2230	2200	2055	1900	1760	1700		kg	
										2200	2055	1900	1760	1700			kg	
										2200	2050	1900	1850				kg	
30,5 m	3,1	▶		18,5	20	22	24	26	28	30	30,5						m	
▲▲▲	▲▲▲	▲▲▲	▲▲▲	4000	3650	3250	2930	2670	2440	2240	2200						kg	
										2200							kg	
										2200							kg	
28,5 m	3,1	▶		19,2	20	22	24	26	28	28,5							m	
▲▲▲	▲▲▲	▲▲▲	▲▲▲	4000	3810	3400	3070	2790	2550	2500							kg	
										2200							kg	
										2200							kg	
40 m	3,1	▶		16,7	18	20	22	24	26	27,4	28	28,5					m	
▲▲▲	▲▲▲	▲▲▲	▲▲▲	4000	3660	3220	2870	2590	2350	2200	2145	2100					kg	
										2200	2145	2100					kg	
										2200							kg	

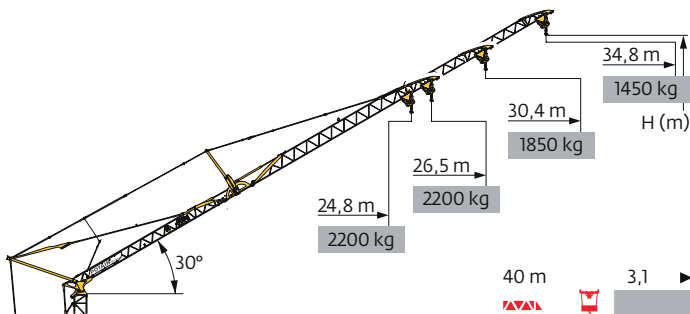

▲▲▲	40 m	35 m	30,5 m	28,5 m
H+1	44,5	42	-	-
H+0	38,5	36	33,7	32,7

40 m	3,1	▶	22,9	24,6	28	31	34,8	m
▲▲▲	▲▲▲	▲▲▲	2200	2000	1715	1510	1300	kg
			2200	1900	1650	1450		kg
35 m	3,1	▶	24,7	26,4	28	30,4	m	
▲▲▲	▲▲▲	▲▲▲	2200	2020	1880	1700	kg	
			2200	2050	1850		kg	
30,5 m	3,1	▶	26,5	m				
▲▲▲	▲▲▲	▲▲▲	2200	kg				
			2200	kg				
28,5 m	3,1	▶	24,8	m				
▲▲▲	▲▲▲	▲▲▲	2200	kg				
			2200	kg				

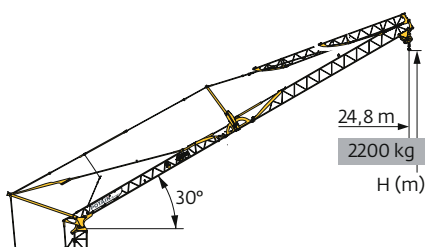

40 m	3,1	▶	24,8	m
▲▲▲	▲▲▲	▲▲▲	2200	kg
			2200	kg

▲▲▲	40 m
▲▲▲	35 m
H+1	-
H+0	32,7

Mécanismes / Triebwerke / Mechanisms / Mecanismos / Meccanismi
 Mecanismos / Механизмы

400 V - 50 Hz 480 V - 60 Hz												ch - PS hp	kW	
	15 LVF 11 Optima	m/min	3,5	18	30	36	68	1,8	9	15	18	34	15	11
		kg	2200	2200	2200	1500	550	4000	4000	4000	3000	1100		
	3 DVF 5	m/min	15 - 30 - 41 (1300 → 4000 kg) 15 - 30 - 45 (0 → 1300 kg)									3	2,2	
	RVF 151 Optima+	tr/min U/min rpm	0 → 0,8									5,5	4	

IEC 60204-32	kVA
400 V (+10% -10%) 50 Hz / 480 V (+6% -10%) 60 Hz	→ 17 kVA → 19 kVA

15 LVF 11 Optima

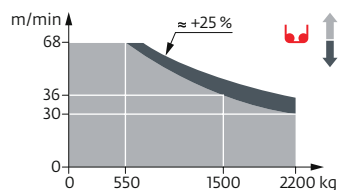

Montage / Montage / Erection / Montaje / Montaggio
 Montagem / Монтаж

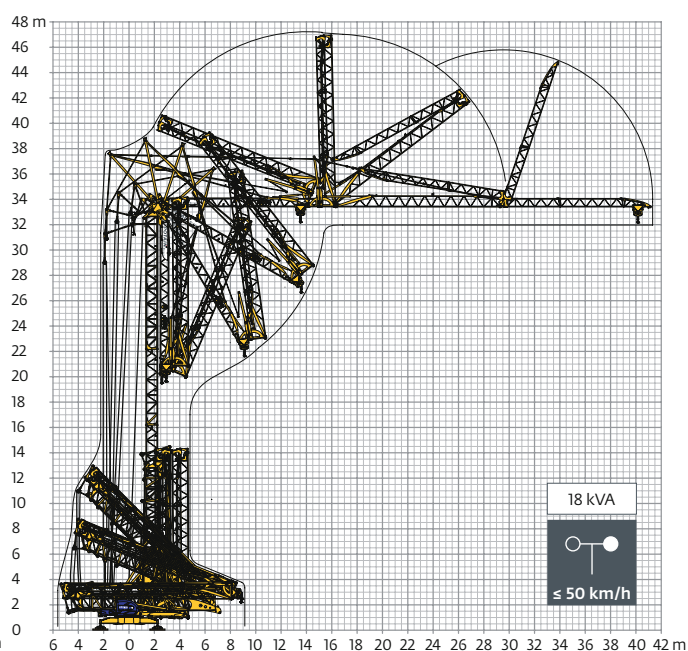
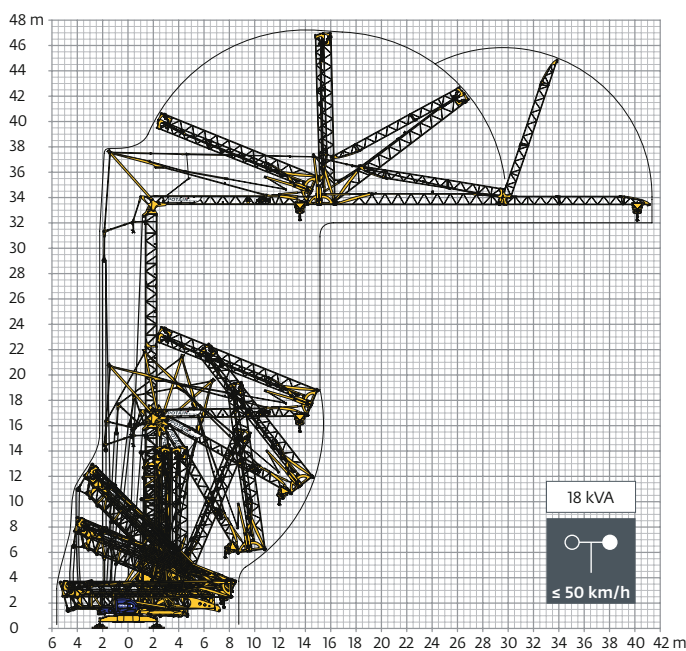

Transport / Transport / Transport / Transporte / Trasporto
Transporte / Транспортировка

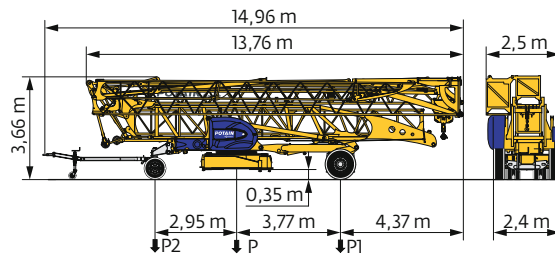

	km/h	P (kg)	P1 (kg)	P2 (kg)
DJ100/S120	10	16970	9540	7430
DJ105/S125	25	17260	9750	7510

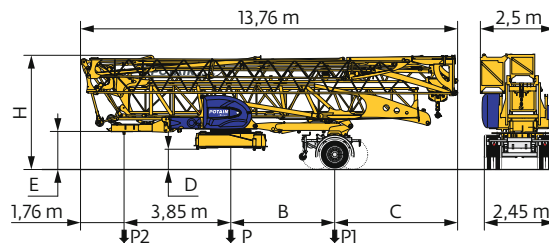

	km/h	B (m)	C (m)	D (m)	E (m)	H (m)	P (kg)	P1 (kg)	P2 (kg)
SL121/J135	25	3,77	4,37	0,77	1,3	4,06	17815	11525	6290
SL122/J215M (EBS) RCE e2*2007/46*0493 WVTA e2*2007/46*0493	80	3,21	4,93	0,66	1,2	3,96	18860	13320	5540

FR

DE

EN

ES

IT

PT

RU

R	Rayon de giration	Schwenk radius	Rear slewing radius	Radio de giro	Raggio di rotazione	Raio de rotação	Задний габарит
i	Nous consulter	Auf Anfrage	Consult us	Consultarnos	Consultateci	Consultar-nos	Проконсультируйтесь у нас
●	Réactions en service	Reaktionskräfte in Betrieb	Reactions in service	Reacciones en servicio	Reazioni in servizio	Reacções em serviço	Реакция при работе
■	Réactions hors service	Reaktionskräfte außer Betrieb	Reactions out of service	Reacciones fuera de servicio	Reazioni fuori servizio	Reacções fora de serviço	Реакция в покое
▲	Poids à vide, sans lest, sans trains de transport, avec flèche maxi. et hauteur standard.	Gewicht ohne Last, ohne Ballast, ohne Transportachsen, mit max. Auslager und Standardhöhe	Weight without load, without ballast, without transport axes, with max. jib and standard height	Peso en vacío, sin lastre, sin trenes de transporte con flecha y altura estandar	Peso a vuoto, senza assali di trasporto, con braccio max e altezza standard.	Peso em vazio, sem lastro, sem eixos de transporte com lança máxima e altura standard.	Вес без груза, без балласта, без осей для транспортировки, с максимальным вылетом стрелы и стандартной высотой
⚖	Poids total du lest	Ballast-Gesamtgewicht	Total ballast weight	Peso total del lastre	Peso totale della zavorra	Peso total do lastro	Общий вес балласта
□	Équipements standards	Standardausrüstungen	Standard equipment	Equipamiento de serie	Equipaggiamento standard	Equipamento de série	Стандартное оборудование
⊞	Équipements optionnels	Sonderausrüstungen	Options	Equipamiento opcional	Equipaggiamento in opzione	Equipamento opcional	Дополнительное оборудование (опция)
⬆	Levage	Heben	Hoisting	Elevación	Sollevamento	Elevação	Подъем
⬆	Distribution	Katzfahren	Trolleying	Distribución	Distribuzione	Distribuição	Перемещение по стреле
⬆	Orientation	Schwenken	Slewing	Orientación	Rotazione	Rotação	Поворот
⬆	Translation	Kranfahren	Travelling	Traslación	Traslazione	Translação	Перемещение крана
kVA	Puissance requise	Erforderliche Leistung	Required power	Potencia Necesaria	Potenza richiesta	Potência Necessária	Потребляемая мощность

!	Document commercial non contractuel. Pour toute information technique se référer à la notice correspondante.	Unverbindliches Vertriebsdokument. Für technische Informationen, siehe die entsprechenden Anweisungen.	This commercial document is not legally binding. For any technical information, please refer to the corresponding instructions.	Documento commercial no contractual. Para cualquier información técnica, ver la noticia correspondiente.	Documento commerciale non vincolante, per tutte le informazioni tecniche fare riferimento al catalogo istruzioni.	Documento comercial não contratual. Para qualquer informação técnica complementar consultar as respectivas instruções.	Этот коммерческий документ не является юридически обязательным. Для получения технической информации, см. соответствующие инструкции.
----------	--------------------------------------------------------------------------------------------------------------	--------------------------------------------------------------------------------------------------------	---------------------------------------------------------------------------------------------------------------------------------	----------------------------------------------------------------------------------------------------------	-------------------------------------------------------------------------------------------------------------------	------------------------------------------------------------------------------------------------------------------------	---------------------------------------------------------------------------------------------------------------------------------------

